

AC drive for single-phase AC motors VersiDrive i ... /E up to 1,1kW 4.07

**Features:**

- ❑ small inverters for single-phase capacitor motors
- ❑ easy programming and connection
- ❑ fixed frequencies adjustable
- ❑ max. rotating field frequency 120Hz
- ❑ DC brake
- ❑ integrated braking chopper (at 1,1kW)
- ❑ degree of protection IP20
- ❑ integrated mains filter (single-phase, class C1 up to 5m)
- ❑ serial communication with Modbus RTU



AC drive  
for single-phase AC motors  
VD i 037 ... 110/E



**Function:**

- ❑ control and setpoint entry via terminals and operating unit
- ❑ PWM clock frequency 4 - 32kHz
- ❑ DC-braking (duration)
- ❑ potential-free control and signalling contacts
- ❑ detailed trouble check with parameter P00

**Typical Applications:**

- pumps
- grinding machines
- ventilators

**Options and braking resistors:**

(please see accessories type VD i ... /E2/3E2)

- ❑ memory stick with copying function
- ❑ remote control module
- ❑ input and output module
- ❑ software for parameterization and operating

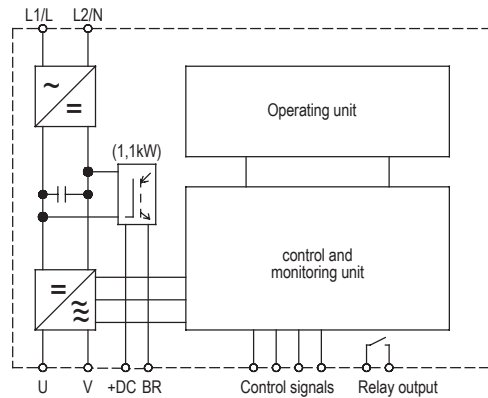

Technical Data	VD i ... /E		
	037	075	110
Motor shaft power / kW	0,37	0,75	1,1
Mains voltage according to DIN EN 50160 (IEC 38)	single-phase 200-240V, 48-62Hz		
Output current/ A	4,3	7	10,5
<b>Control functions</b>			
Frequency setting range	0 – 120Hz		
Torque boost	U/f-characteristic, adjustable via parameter setting		
Ramp-up and ramp-down time	0 ... 600s		
Frequency setpoint	potentiometer >= 1kW, 0-10V, 4-20mA, keypad, fixed frequencies, motor potentiometer, Modbus RTU		
Ambient / Storage temperature	-10 ... 50° / -40 ... 60°C		
Weight / kg	1,1	1,1	2,6
Order number	21002.23037	21002.23075	21002.23110

## Dimensions:

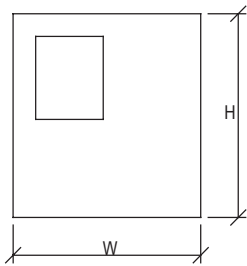

	W [mm]	H [mm]	D [mm]
VD i 037/E	82	173	123
VD i 075/E	82	173	123
VD i 110/E	109	221	150

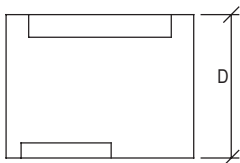

## Connection Diagram:

